

STEP-KO
PRODUCTS



FLANGE ISOLATION KITS

HONORED AS TOP EMERGING COMPANY

With a modest team of 16 employees, including his wife, Sara, Eunice native Byron Stephens is leading what Louisiana Economic Development has hailed as the small emerging business of 2015. Stephens started his energy service company on Petroleum Parkway in Broussard 15 years ago. The company provides corrosion protection products such as pipe wrap tape, gasket kits, and pipeline markers to 42 countries around the world.

Businesses like Step-Ko LLC are an economic driver for the state, LED secretary Stephen Moret said. "Small businesses could not be more important to Louisiana, delivering goods and services that fuel our economy across every industry section and in every geographical region of our state," Moret said.

* Excerpt from the Sunday Advertiser: Written by Jessica Goff



ABOUT STEP-KO

Step-Ko Products was founded in 2000 because of a need to provide clients in the Oil & Gas and Industrial markets responsive, professional, and courteous sales help. Over a decade later, STEP-KO PRODUCTS, LLC is a global provider of corrosion protective products, with sales in over 42 countries, and professional sales representatives around the world. STEP-KO PRODUCTS, LLC focuses on providing clients with affordable solutions to their corrosion protection needs. Our professional and courteous staff will take the time necessary to understand your needs and ensure you are receiving products and resources that are essential to protecting your greatest assets, which include your personnel, equipment, and environment. The company is a proven innovator in corrosion protective equipment. STEP-KO PRODUCTS, LLC is constantly researching future protection technology in order to provide creative and innovative solutions for your corrosion protection needs.

INTRODUCTION

The Step-Ko Products Flange Isolation Gasket Kits are designed to maintain the integrity and reliability of the pipeline and piping system through safety and corrosion protection. Flange Isolation Gasket Kits provide both an effective seal and reliable electrical isolation of flanges. By eliminating metal to metal contact, static current is halted to prevent corrosion and aid in the Cathodic protection of the piping system.

Constructed of high quality materials that have a high dielectric constant and low water absorption, our Flange Isolation Gasket Kits are available in various configurations to meet every possible need.

We offer Flange Isolation Gasket Kits in all sizes, ranging from 1/2" to 144", in all Ansi and API classes. Custom and Special sizes are also available upon request.

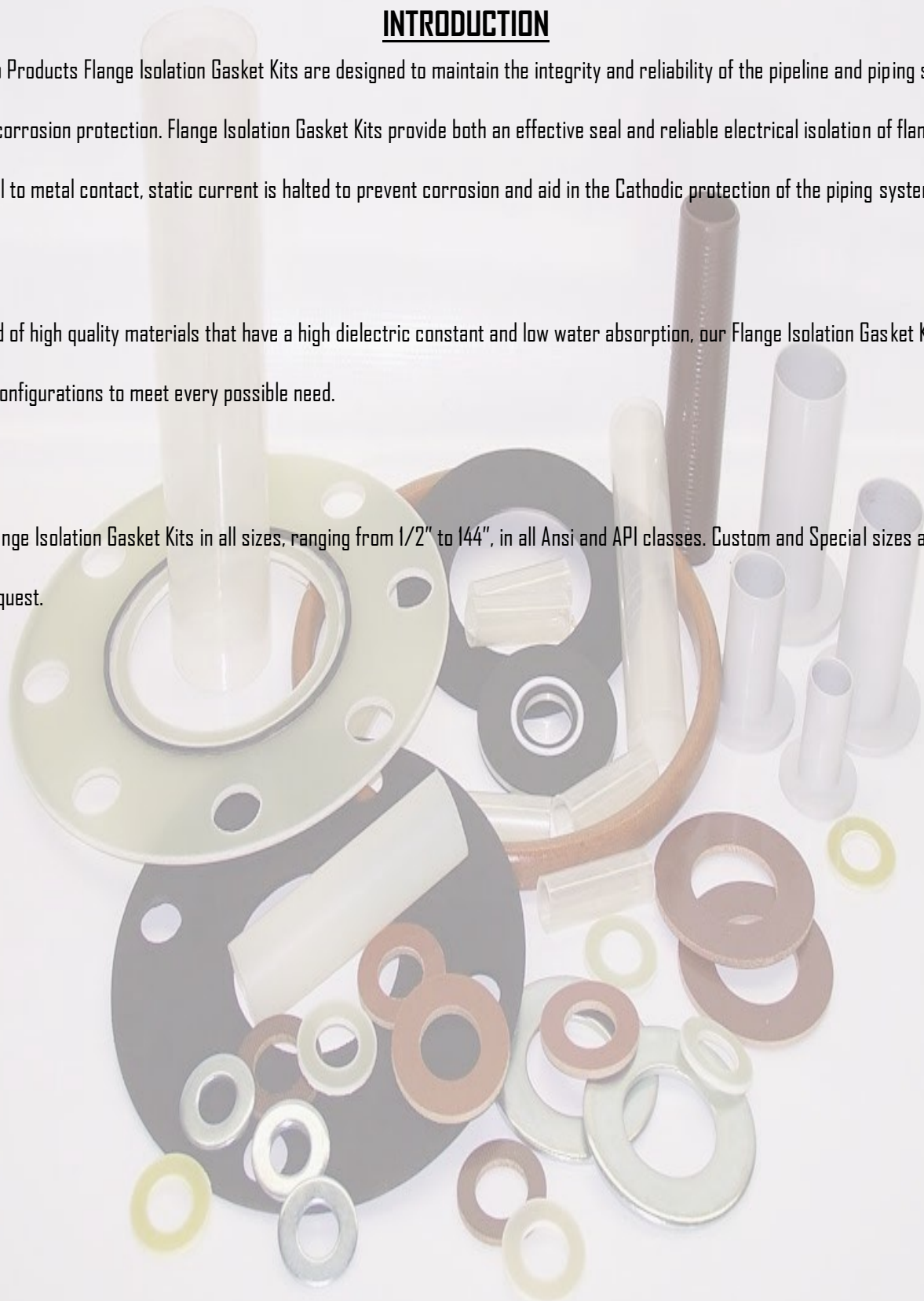

GASKET KIT TYPES

Type E

This Style kit contains a full face gasket that has the same outside diameter as the flanges. This style gasket will prevent foreign material from collecting and creating a bridge, thus shorting the cathodic isolation. Type E gaskets are available in phenolic, neoprene-faced phenolic, and high temperature materials. Type "E" gaskets may be ordered in any one of the following.

- Warrior Gaskets
- Neoprene Faced Phenolic Gaskets
- Plain Phenolic Gaskets

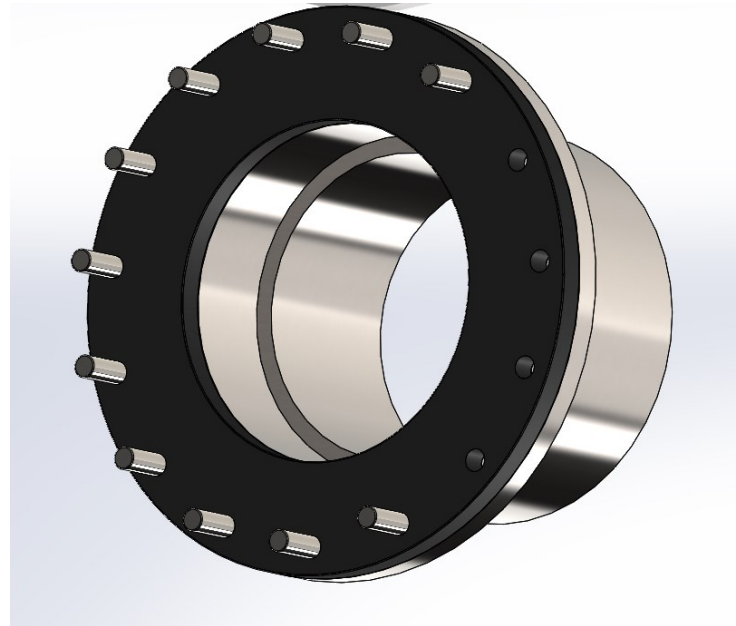

Type F

This gasket will fit only the raised surface of the flanges. The outside diameter of the gasket is slightly less than the inside diameter of the bolt circle. This gasket can be used on both raised face and full face flanges. It is recommended that the flanges are wrapped with Flange Band Protectors to prevent foreign material from collecting and creating a bridge, thus shorting out the isolation. Type F gaskets are available in same material as Type E.



Type D

Type D gaskets are designed to fit into the ring groove of RTJ flanges. We also offer BX gaskets. Both are available in grade GE phenolic.

ISOLATING GASKETS

WARRIOR® Gaskets

Warrior gaskets are one of the most effective ways to seal and isolate flanges. The gasket consists of a dielectric retainer containing a metal seal on each side. Due to the sealing elements design sealing can be achieved without large bolt loads. Each gasket is manufactured using state of the art CNC equipment ensuring tight tolerances are achieved. This allows the Warrior gaskets to be used in a variety of applications including mismatch flanges, misaligned flanges and RTJ style flanges. Warrior Gaskets are offered in a wide variety of retainer materials and sealing element combinations to match your service environment.

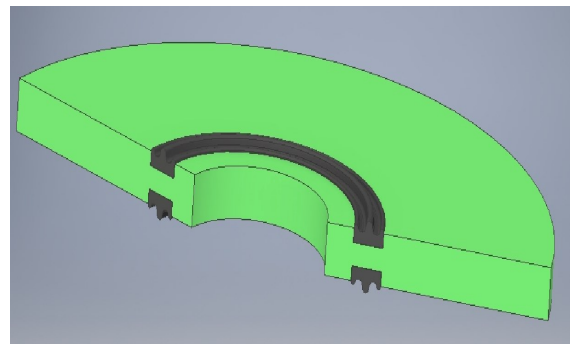

Neoprene Faced Phenolic Gaskets

Neoprene Faced Phenolic gaskets have been used in the oil and gas industries for many years. Neoprene Sheets are factory applied to both sides of a laminated phenolic sheet providing an effective sealing surface. The temperature limit of these gaskets is 175° F (80° C.).

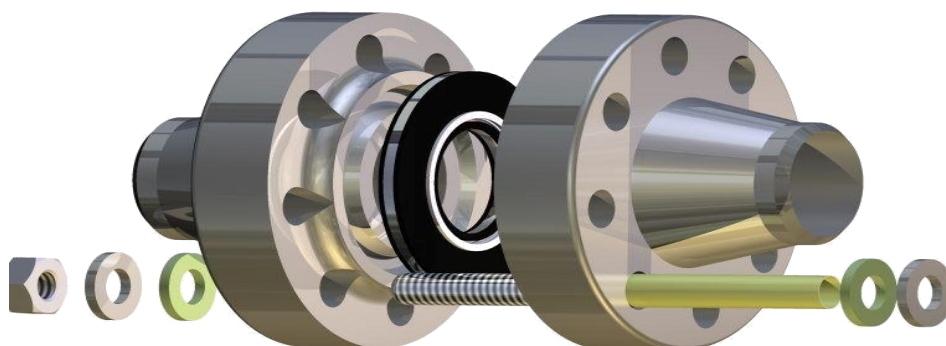

SLEEVES AND WASHERS

Isolating Sleeves

Isolating sleeves are available in the following materials:

- Mylar
- Polyethylene
- Phenolic
- Nomex
- G-7 Silicon Glass
- G-10 Epoxy Glass

Designed to easily fit over standard sized & flange bolt/studs within standard size & bolt holes, isolating sleeves have a wall thickness of 1/32", and are used with separate isolating and steel washers. They are available for standard American bolt sizes from 1/2" to 3-1/2" as well as metric bolt sizes from 12mm and larger.

Isolating Washers – Standard 1/8" Thick

Isolating washers are available in the following materials:

- Phenolic
- G-3 High Temp. Phenolic
- G-7 Silicon Glass
- G-10 Epoxy Glass

Designed to provide tough, positive isolation. Isolating washers are available for bolt sizes from 1/2" to 3 1/2" and are made to fit over the isolating sleeves.

One-Piece Sleeves and Washers

Molded from Minlon, and available for bolt diameters from 1/2" to 1-1/2", one-piece sleeves and washers are structurally tough but limited to applications where the flange temperature does not exceed +180°F, and compressive loads do not exceed 18,000 psi.

They are typically used as single washer sets because they're molded to specific lengths and, in many instances, are longer than the thickness of a single flange.

Steel Washers

Steel washers are designed to fit over the isolating sleeve, or the retainer ring, the one-piece sleeves and washers. The outside diameter is sized to fit within the bolt facing on ANSI standard flanges. Standard with Zinc Plated are also available in 316 stainless and Teflon Coated.



SPECIFICATIONS

Washer Material Physical Properties

Material	Dielectric Strength	Water Absorption	Compressive Strength	Maximum Temperature
Phenolic	400 vpm	1.10%	25,000 psi	225° F 107° C
G-7	350-400 vpm	0.07%	40,000 psi	450° F 232° C
G-10	550 vpm	0.10%	50,000 psi	285° F 141° C

* **Special & High Temperature: Available upon request.**

* G-7 Material should not be used with hydrocarbons, not even trace amounts.

Sleeve Material Physical Properties

Material	Dielectric Strength	Water Absorption	Flexural Strength	Maximum Temperature
Mylar	4000 vpm	0.80%	13,000 psi	300° F 149° C
Integral Minlon	1200 vpm	0.22%	1,400 psi	200° F 93° C
Polyethylene	400 vpm	0.01%	7,000 psi	105° F 41° C
Phenolic	400 vpm	2%	16,000 psi	225° F 107° C
G-10	550 vpm	0.10%	55,000 psi	285° F 141° C
Nomex	400 vpm	N/A	20,000 psi	450° F 232° C

* G-7 Material should not be used with hydrocarbons, not even trace amounts.

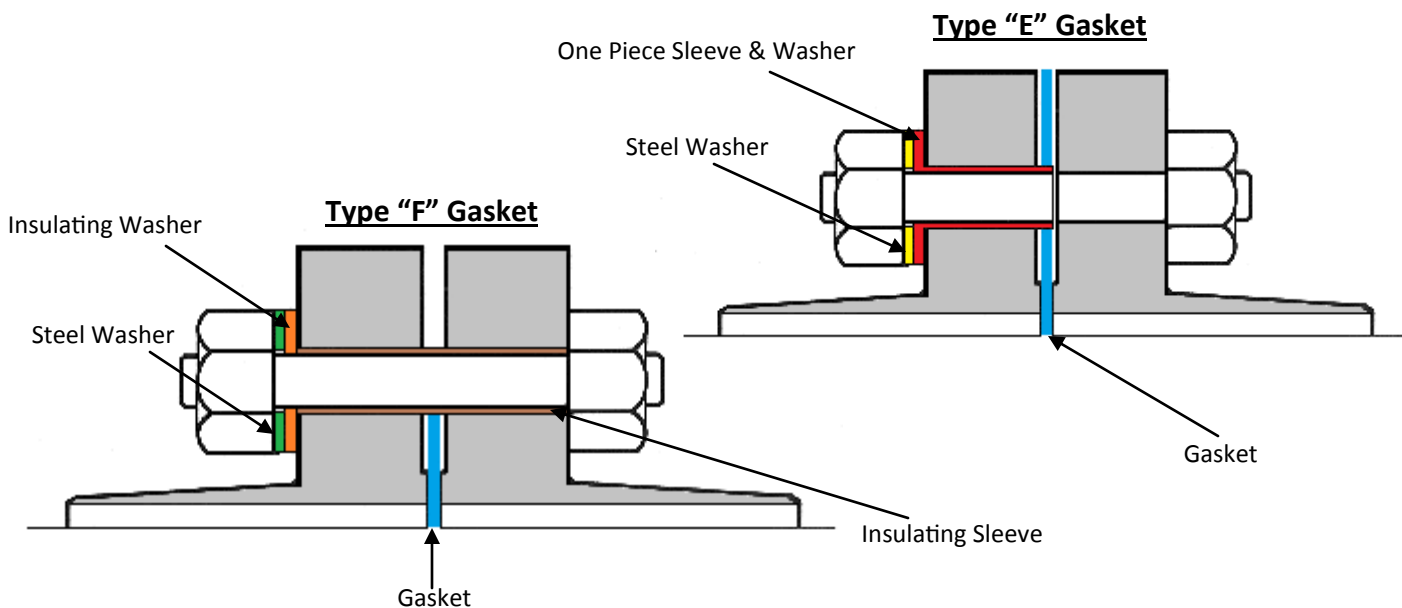

FLANGE ISOLATION KITS

Flange Isolation Kits

Flange Isolation Kits are available for all flange sizes, types, pressure ratings and materials. Each kit is packaged in a reinforced corrugated cardboard box, which is labeled by its contents for convenience in warehousing and field use. Large diameter gaskets are packaged separately from the sleeves and washers for convenience.

Each gasket is labeled with:

- Materials (Retainer Material or Retainer/Seal Element Combination)
- Pipe Size
- ANSI Class
- Date of Manufacture

Sleeves and Washers

Sleeves and washers are enclosed in a polyethylene bag to eliminate any possibility of loss. A chart showing the recommended sequence for tightening flange bolts is also included with each kit.



Sealing Gasket Physical Properties

Material	Dielectric Strength	Water Absorption	Compressive Strength	Maximum Temperature
Plain Faced Phenolic	500 vpm	1.50%	25,000 psi	225° F 107° C
Neoprene Faced Phenolic	500 vpm	1.50%	25,000 psi	175° F 79° C
G-7	350-400 vpm	0.07%	40,000 psi	450° F 232° C
G-10	550 vpm	0.10%	50,000 psi	285° F 141° C

*Consider **both** retainer and seal element temperature limits together for Warrior® Sealing Gaskets.

Sealing Element Temperature Limits

	Viton	Teflon
Degrees Fahrenheit	-20 to +350	Cryogenic to +450
Degrees Celsius	-29 to +177	Cryogenic to +232

Single Washer Set

Single washer set flange isolation kits include the following items for each bolt:

- One - 1/8" thick steel washer
- One - Isolating washer
- One - Isolating sleeve

Application

Single washer sets may be used to allow the Cathodic Protection current to reach the nuts and bolts. Nuts on the opposite side of the cathodically protected flange may be included.

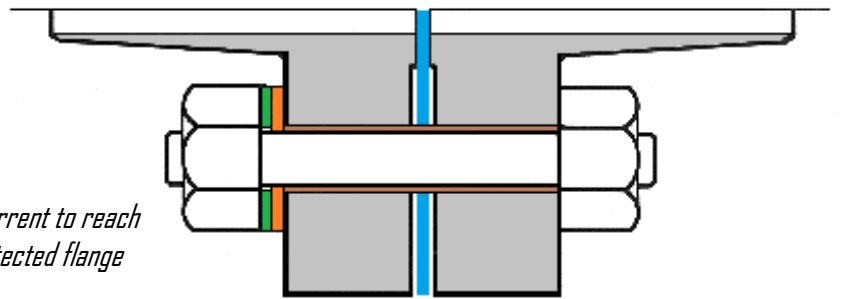

Double Washer Set

Double washer set flange isolation kits include the following components for each bolt:

- Two - 1/8" thick steel washers
- Two - Isolating washers
- One - Full length isolating sleeve

Application

Double washer sets may be used for added protection. Double washer sets also electrically isolate the nuts and bolts from both flanges.

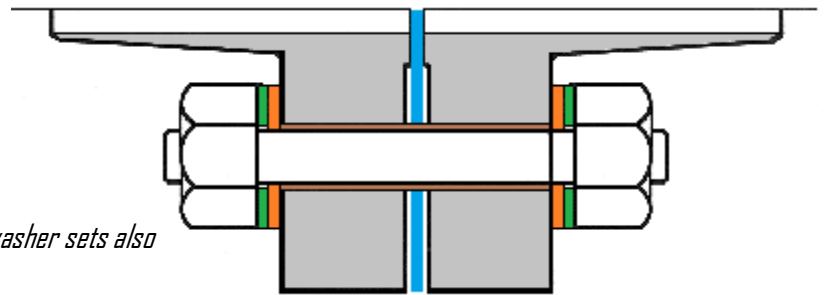

One-Piece Sleeve and Washer Sets

One-piece sleeve and washer set flange isolation kits include the following items for each bolt:

- Two - 1/8" thick steel washers
- One - One piece Isolating sleeve

Application

Easy to install, one-piece sleeves also allow the inspector a visual indication of sleeve usage. Because of the low compression strength on this material, please do not use for high pressure or large diameter flanges.

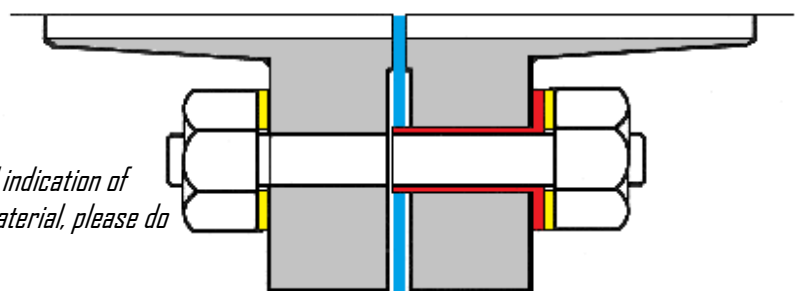



TO: _____ DATE: _____

COMPANY NAME: _____

PHONE NUMBER: _____ FAX NUMBER: _____

FROM: _____ YOUR REF# _____

GASKET SPECIFICATIONS

THIS FORM MUST BE FILLED OUT IF ORDERING GASKETS LARGER THAN 24" IN ORDER FOR STEP-KO TO MANUFACTURE THEM CORRECTLY

TYPE OF CONNECTION: STANDARD FLANGE VALVE (Circle One)

FLANGE SPEC: _____ (i.e. AWWA, MSS SP-44)

NOMINAL SIZE: _____ PRESSURE RATING: _____

ACTUAL I.D. _____ (important for the gasket to seal properly)

FLANGE O.D. _____

BOLT CIRCLE: _____

NUMBER OF BOLT HOLES: _____

BOLT HOLE DIAMETER: _____ BOLT SIZE: _____

FLANGE #1 THICKNESS: _____ FLANGE # 2 THICKNESS: _____

If flanges are not identical, you must specify both flange thicknesses for sleeves to fit properly.

Note: Insulating sleeves are designed to fit over all-threaded studs. When using shoulder bolts (bolts with a shank) the sleeves may not fit over the shoulder bolt shank. It may be necessary to machine down the shaft to match the diameter of the threads.

YOUR SIGNATURE: _____

Warranty

All products are warranted against failure caused by manufacturing defects for a period of one year. Any product found to be defective, and returned within one year from date of shipment, will be replaced without charge.

The above warranty is made in lieu of, and we disclaim, any and all other warranties, expressed or implied, including the warranties of merchantability and fitness for a particular purpose, and buyer agrees to accept the products without any such warranties.

We hereby disclaim any obligation or liability for consequential damages, labor costs and any other claims, or liabilities, of any kind whatsoever.

How To Order

1. Specify flange size and pressure rating.
2. Specify gasket type: D, E, or F.
3. Specify single washer or double washer.
4. Consult factory for specials.

OTHER PRODUCTS

- Heat Shrink Sleeves
 - Pipe Wrap Tapes
- Flange Protectors and Nut Caps
- Insulated Buildings and Enclosures
 - Specialty Pipeline Coatings
 - Anodes
- Pipeline Markers and Test Stations

PROTECTING ASSETS FROM THE ENVIRONMENT

STEP-KO
PRODUCTS

P.O. Box 81396 Lafayette, LA 70598

Telephone: 337.837.4141 Fax: 337.837.4095

WWW.STEPKO.COM



MADE IN



U. S. A.

